



Automatic power factor controller, 8 steps, icon display
DCRL8

Product designation

Product type designation

Auxiliary supply

Rated auxiliary supply voltage U_s

AC

min	VAC	100
Max	VAC	440

DC

min	VDC	110
Max	VDC	250

Auxiliary operating range

90...484VAC /
93.5...300VDC

Auxiliary rated frequency

Hz 50/60 $\pm 10\%$

Power consumption Max

VA 8.5

Power dissipation Max

W 3

Immunity time for microbreakings

ms <25

Voltage inputs

Rated voltage (U_e)

VAC 600VAC L-L
(rated max)

Operating range

50...720VAC L-L
(415VAC L-N)

Frequency range

Hz 45...65

Type of measure

True RMS value

No-voltage release

ms =8

Measurement input impedance

k Ω >15M Ω

Type of connection

Single phase, two
phase, three
phase with or
without neutral or
balanced three
phase system

Current inputs

Number of current input

Nr. 1

Type of input

Shunt supplied
by external
current
transformer (low
voltage). Max 5A

Measurement range

0.025...6A~ for
5A scale;
0.025...1.2A~ for
1A scale

Measurement method

True RMS value

Constant overload

I_e 1.2 I_e

Overload peak	A	50A for 1s
Burden per phase	W	<0.6VA
Measurement data		
Type of voltage and current measurement		True RMS value
Power factor adjustment		0.5ind...0.5cap.
Type of temperature sensor		Internal
Temperature measurement range	°C	0...+212
Relay outputs		
Number of relay output	Nr.	8 (up to 14 with EXP10 06 - EXP10 07)
Contact arrangement		7 NO-SPST + 1 C/O-SPDT
Rated current		5A 250V AC1
UL/CSA and IEC/EN 60947-5-1 designation		B300
Maximum current at common contact terminal	A	10
Maximum switching voltage	VAC	415
Electrical life (with rated load)	cycles	105
Mechanical life	cycles	107
Insulations		
Rated insulation voltage Ui IEC/EN	V	600
Rated impulse withstand voltage Uimp	kV	9.5
Operating frequency withstand voltage	kV	5.2
Connections		
Type of terminal		Plug-in, removable
Conductor cross section		
	min	mm ² 0.2
	Max	mm ² 2.5
	min	AWG 24AWG (18AWG according to UL/CSA)
	Max	AWG 12
Tightening torque (Max)		
		Nm 0.56
		lbin 5
Ambient conditions		
Temperature		
Operating temperature		
	min	°C -20
	max	°C +60
Storage temperature		
	min	°C -30
	max	°C +80
Relative humidity	%	<80%
Maximum Pollution degree		2
Overvoltage category		3
Measurement category		III
Climatic sequence		Z/ABDM (IEC/EN 60068-2-61)
Shock resistance		15g (IEC/EN 60068-2-27)
Vibration resistance		0.7g (IEC/EN 60068-2-6)

Housing

Execution	Flush mount
Material	Polycarbonate
Mounting	Flush-mount 144x144mm (5.67x5.67")
Degree of protection	IP65 on front with gasket, if mounted in class IP65 panel or better. IP20 terminals
Dimensions (W x H x D)	mm 144 x 144 x 53.2
Weight	g 640

Dimensions

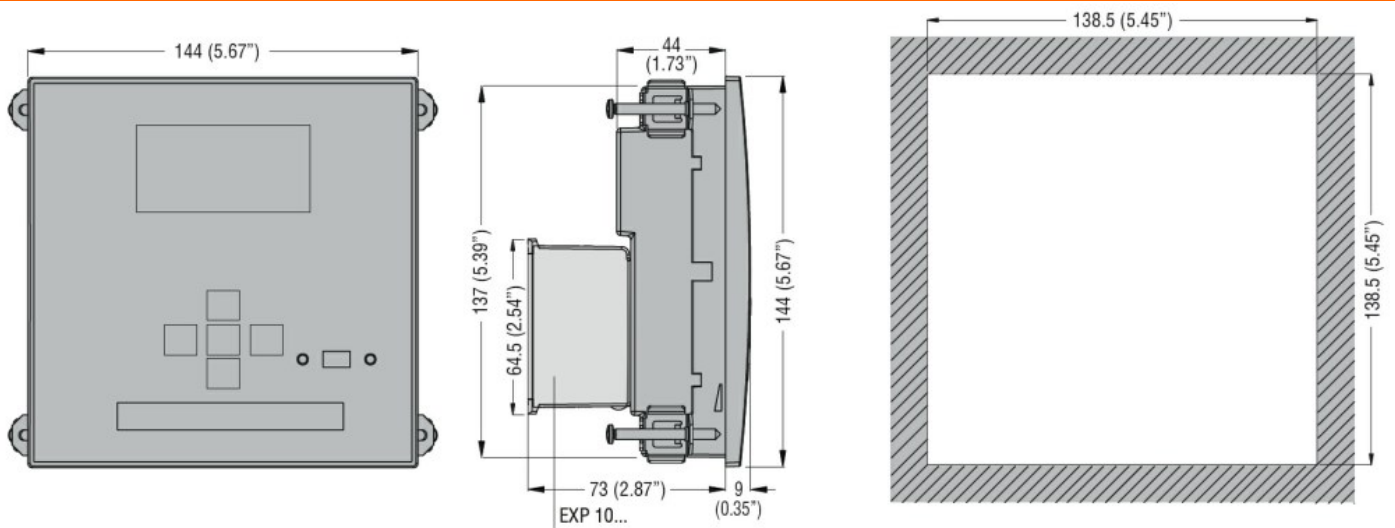

Wiring diagrams

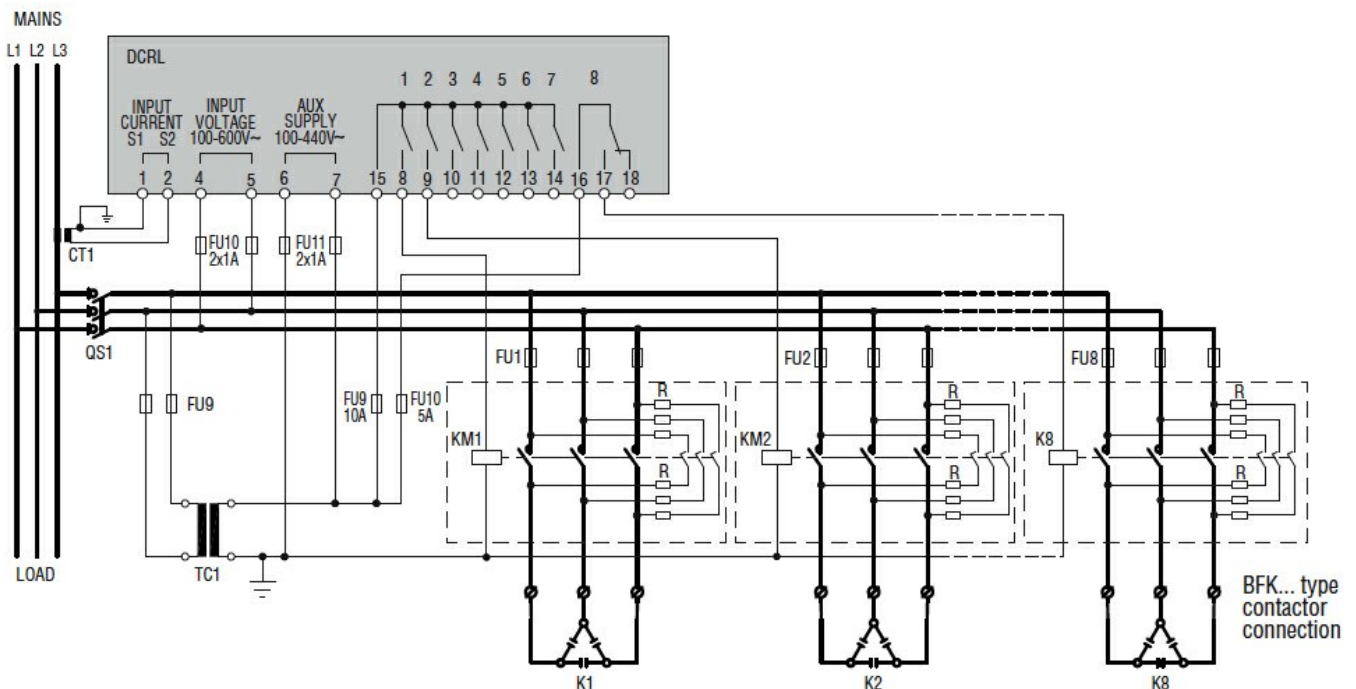

Certifications and compliance

Compliance

CSA C22.2-N°14

IEC/EN 61000-6-2

IEC/EN 61000-6-3

IEC/EN 61010-1

IEC/EN 61010-2-030

UL508

Certificates

cULus

EAC

RCM

ETIM classification

ETIM 8.0

EC001443 -
Effective power
(cos phi)
monitoring relay